

# AQ-SPK6.5-4HS SPORT SERIES

## WATERPROOF SPEAKERS with ADJUSTABLE TWEETER

### FOR HARLEY-DAVIDSON® MOTORCYCLES



#### SPECIFICATIONS

Type:	Full-range, 2-way waterproof speaker
Cone Size:	6.5"
Tweeter Size:	57mm
Outside Diameter:	167.8mm (includes mounting ring)
Mounting Hole Diameter:	144mm
Mounting Depth:	70mm
Impedance:	4 Ohm
Frequency Response:	65Hz - 20,000Hz
Cross-Over:	12db/Octave
Sensitivity:	86dB
Power (max):	200W (2x 100W)
Power (RMS):	100W (2x 50W)
Waterproof:	Yes
Basket Material:	Aluminum
Cone Material:	PP Injection
Additional Features:	Adjustable Tweeter direction
Accessories:	Mounting Ring & Hardware (included)

#### DIMENSIONS

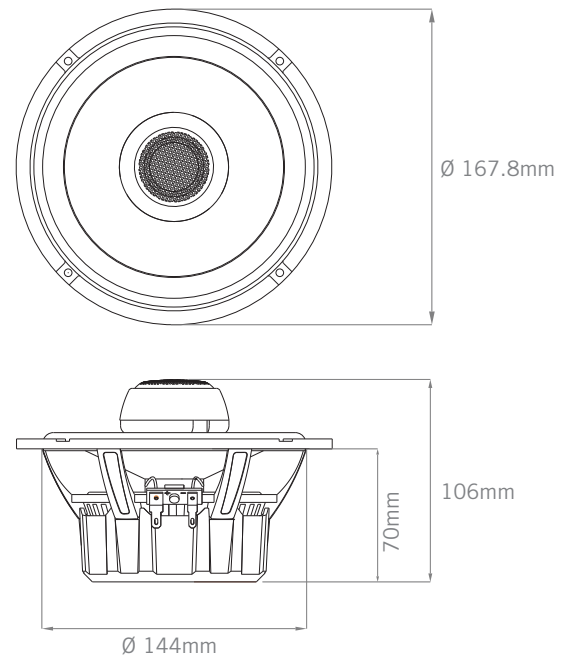

#### Aquatic AV

282 Kinney Drive  
San Jose, CA 95112, USA

E-mail: [info@aquaticav.com](mailto:info@aquaticav.com)

US & Canada: 1 877 579 2782

International: +1 408 559 1668

Fax: +1 408 559 0125

[www.aquaticav.com/harley](http://www.aquaticav.com/harley)

Design and specification subject to change without notice. E&OE