

# AQ-SPK6.5-4HB

## WATERPROOF SPEAKERS with ADJUSTABLE TWEETER

### FOR HARLEY-DAVIDSON® MOTORCYCLES



Adjustable tweeter direction to improve sound quality when travelling at speed!



**Includes Grill, Mounting Ring & Hardware**

1998-2013 models require grill & mounting ring (included).  
2014+ models do not require grill & mounting ring.

#### SPECIFICATIONS

<b>Type:</b>	Full-range, 2-way waterproof speaker
<b>Cone Size:</b>	6.5"
<b>Tweeter Size:</b>	1" / 25mm
<b>Outside Grill Diameter:</b>	167mm
<b>Mounting Hole Diameter:</b>	144mm
<b>Mounting Depth:</b>	69.2mm
<b>Impedance:</b>	4 Ohm
<b>Frequency Response:</b>	60Hz - 20,000 Hz
<b>Cross-Over</b>	12db/Octave
<b>Sensitivity:</b>	87dB
<b>Power (max):</b>	360W (2x 180W)
<b>Power (RMS):</b>	180W (2x 90W)
<b>Waterproof:</b>	Yes
<b>Grill Material:</b>	UV Plastic, 500hrs stable
<b>Basket Material:</b>	Aluminum
<b>Cone Material:</b>	Complex Fibre
<b>Tweeter Material:</b>	Silk Neodymium
<b>Magnet Material:</b>	14.3oz Neodymium
<b>Additional Features:</b>	Adjustable Tweeter
<b>Accessories:</b>	Grill, Mounting Ring & Hardware (all included)

#### DIMENSIONS

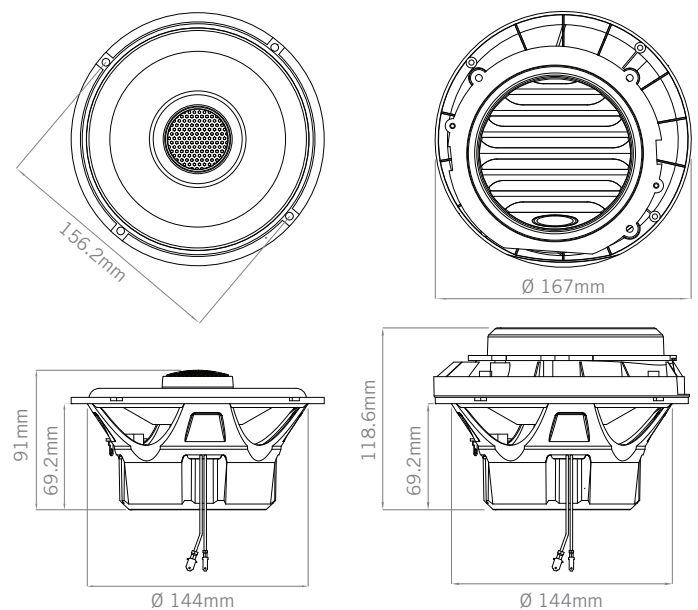

#### Aquatic AV

282 Kinney Drive  
San Jose, CA 95112, USA

E-mail: [info@aquaticav.com](mailto:info@aquaticav.com)

US & Canada: 1 877 579 2782

International: +1 408 559 1668

Fax: +1 408 559 0125

[www.aquaticav.com](http://www.aquaticav.com)

Design and specification subject to change without notice. E&OE