

Source Unit

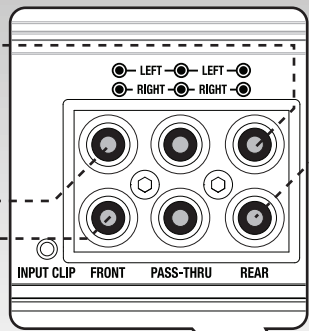

*Keep grounds as short as possible

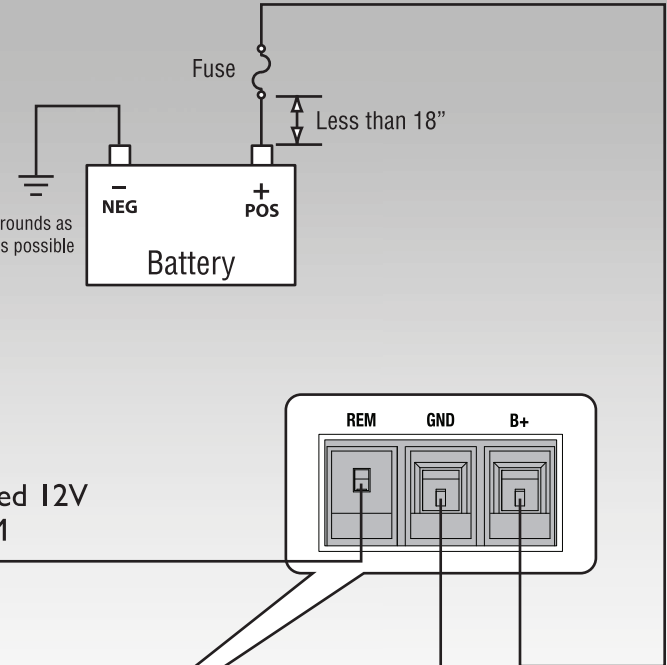

Switched 12V to REM

Connect to chassis ground of vehicle

*Keep grounds as short as possible

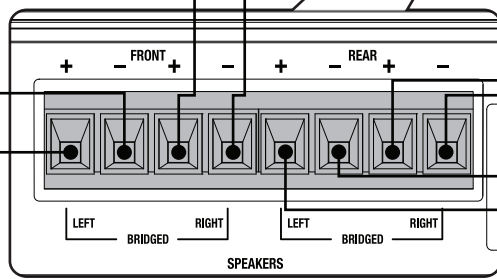
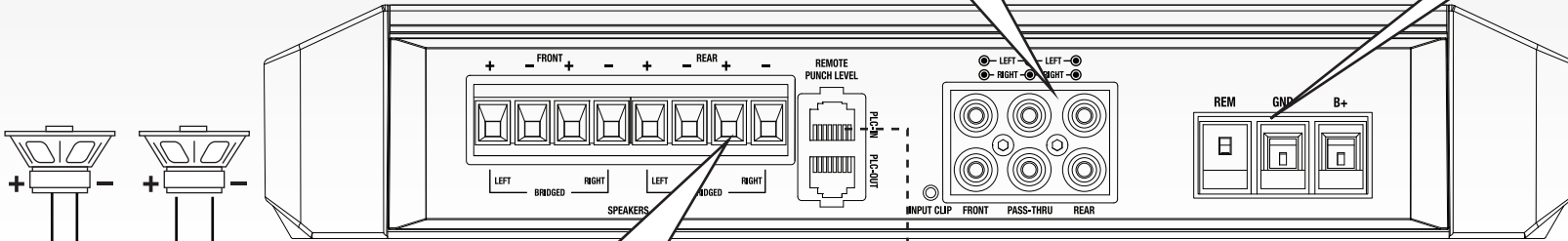

CAUTION
Be sure to connect speakers and Punch Level Control - PLC (if equipped) after amplifier output clip adjustment. (see reverse)

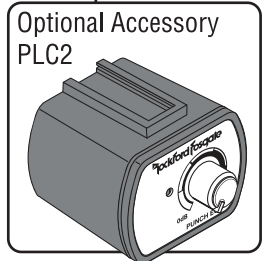

Step 1 - Input

Input Clip Indicator Setup

Be sure to disconnect all speakers from the amplifier.

CAUTION

Failure to comply may cause damage to connected components and/or amplifier.

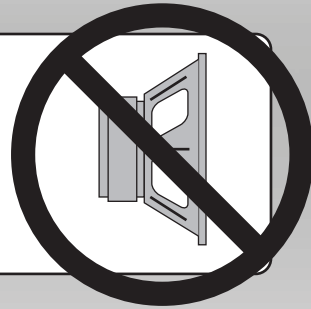

Step 2 - Input

Turn on the source unit with volume set to zero.

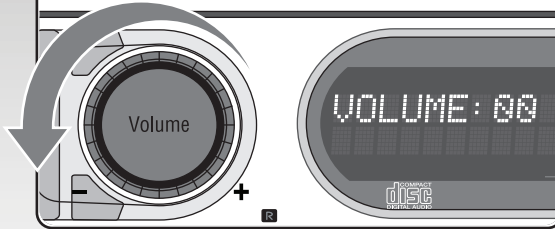

Step 3 - Input

Adjust the Bass & Treble levels on the source unit to flat.

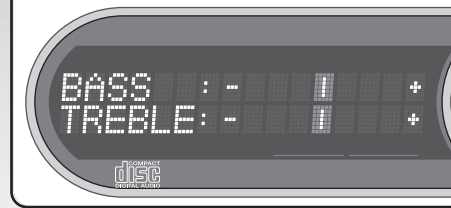

Step 4 - Input

Insert test tone or music CD to play for setup.

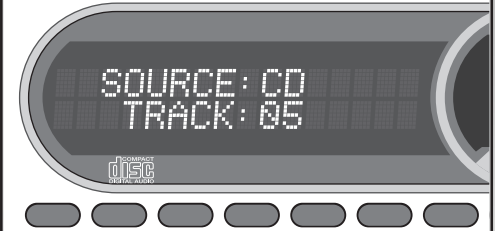

Note: Use the 40Hz @ 0dB tone (Track 5) for mono amplifier applications or the 1kHz @ 0dB tone (Track 7) for multi-channel amplifier applications. Be sure your x-over is switched to the appropriate filter setting.

Step 5 - Input

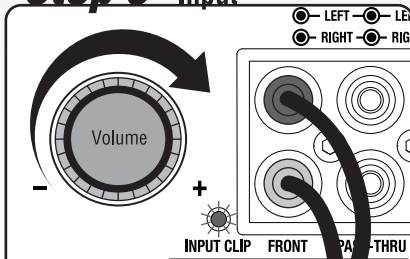

Increase the source unit volume until the Input Clip Indicator illuminates red.

Note: Input Clip can be viewed remotely with optional PLC2.

Step 6 - Input

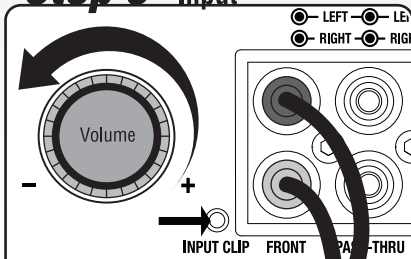

Decrease the source unit volume slightly until the light turns completely off. This establishes your maximum source unit volume for adjusting the Output Clip Indicator.

Note: Some source units will not clip.

Step 7 - Output

Be sure to disconnect Punch Level Control - PLC (if equipped) from the amplifier.

Step 8 - Output

Output Clip Indicator Setup

OUTPUT CLIP INDICATORS	
MUSIC	TEST TONE
BLUE	<input type="checkbox"/>
BLUE/RED	<input checked="" type="checkbox"/>
RED	<input type="checkbox"/>

Adjust the Input Level knob until the Output Clip Indicator illuminates to the appropriate color. Repeat for all channel levels of input.

Step 9 - Output

Turn the source unit volume down.

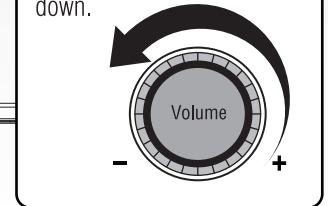

Step 10 - Output

Reconnect all speakers and Punch Level Control - PLC (if equipped) to the amplifier. Be sure to maintain proper speaker polarity.

