

# AQ-MP-5BT-H WATERPROOF MEDIA PLAYER

## HARLEY DAVIDSON MOTORCYCLE - FACTORY REPLACEMENT STEREO



Bluetooth **mp3**



Uses existing Harley mounting location, screws and screw holes.

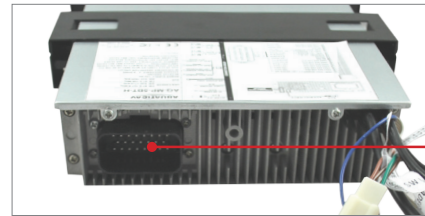

Plug & Play with existing Harley wiring harness.



### SPECIFICATIONS

<b>Supported Media:</b>	Bluetooth/MP3/AM/FM <i>Fits devices up to the size of Samsung Galaxy Note and iPhone 6 Plus.</i>
<b>Display:</b>	Dot Matrix LCD
<b>Detachable Faceplate:</b>	Yes
<b>Inputs:</b>	Bluetooth, 1x 3.5mm stereo jack, 1x stereo pair RCA
<b>Outputs:</b>	1x pair RCA Pre-out (2V)
<b>AM/FM Tuner:</b>	18x FM, 12x AM pre-set memory. US/Euro frequencies
<b>Power (max):</b>	4x 45W (4 Ohms), 4x 72W (2 Ohms)
<b>Amplifier Type:</b>	Class A/B (2 Ohm stable)
<b>Output Voltage:</b>	9.6V - 14.4V DC
<b>Current Draw:</b>	7A (max) / 6mA (standby)
<b>Waterproof:</b>	IP65
<b>UV Protection:</b>	500hrs stable
<b>Salt/Fog Protection:</b>	500hrs stable
<b>Certifications:</b>	CE, RoHS, WEE, FCC
<b>Fascia Material:</b>	ABS
<b>Chassis Material:</b>	ZAM Coated
<b>Accessories:</b>	AQ-WR-5F Remote Control (sold separately)
<b>Additional Features:</b>	Removable Faceplate Bass/Treble, Balance/Fader, Loudness Stainless Steel mounting hardware

### DIMENSIONS

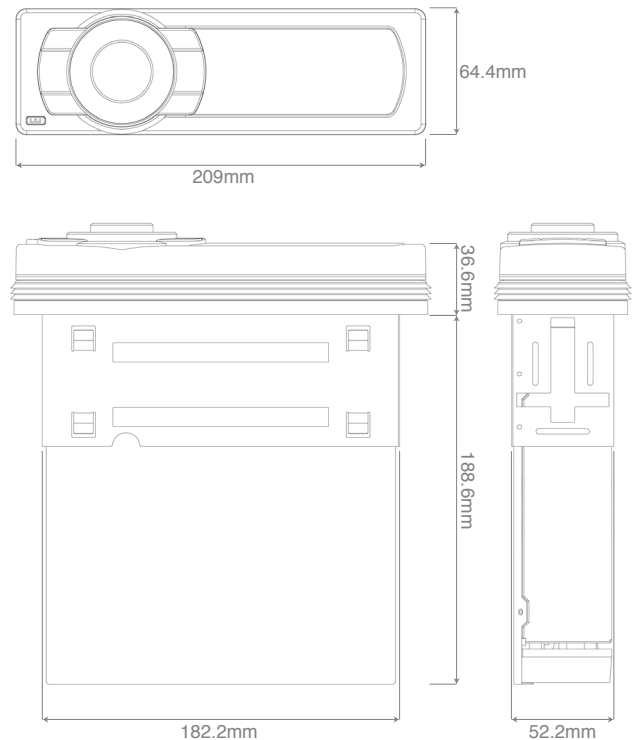

Patent: 7,831,756 & 8,578,081

### Aquatic AV

282 Kinney Drive  
San Jose, CA 95112, USA

E-mail: info@aquaticav.com  
US & Canada: 1 877 579 2782  
International: +1 408 559 1668  
Fax: +1 408 559 0125

www.aquaticav.com

Design and specification subject to change without notice.E&OE