



PUNICH®

DIGITAL MEDIA
RECEIVER

PMX-2



Serial Number: _____ Date of Purchase: _____

600 South Rockford Drive • Tempe, Arizona 85281 United States
Direct: (480) 967-3665 • Toll Free: (800) 669-9899

ROCKFORDFOSGATE.COM



Installation & Operation

Dear Customer,

Congratulations on your purchase of the world's finest brand of audio products. At Rockford Fosgate we are fanatics about musical reproduction at its best, and we are pleased you chose our product. Through years of engineering expertise, hand craftsmanship and critical testing procedures, we have created a wide range of products that reproduce music with all the clarity and richness you deserve.

For maximum performance we recommend you have your new Rockford Fosgate product installed by an Authorized Rockford Fosgate Dealer, as we provide specialized training through Rockford Technical Training Institute (RTTI). Please read your warranty and retain your receipt and original carton for possible future use.

Great product and competent installations are only a piece of the puzzle when it comes to your system. Make sure that your installer is using 100% authentic installation accessories from Rockford Fosgate in your installation. Rockford Fosgate has everything from RCA cables and speaker wire to power wire and battery connectors. Insist on it! After all, your new system deserves nothing but the best.

To add the finishing touch to your new Rockford Fosgate image, order your Rockford accessories, which include everything from T-shirts to hats.

Visit our web site for the latest information on all Rockford products; www.rockfordfosgate.com or, in the U.S. call 1-800-669-9899 or FAX 1-800-398-3985. For all other countries, call +001-480-967-3565 or FAX +001-480-966-3983.

Table of Contents

- 2 Introduction
- 3 Specifications
- 4 Design Features
- 5 Wiring
- 6 Installation/Mounting
- 7-10 Operation
 - Settings
 - Tuner (AM/FM/WB)
 - USB-iPod
 - AUX (Auxiliary Input)
 - Bluetooth®
 - Pandora®
- 11 Troubleshooting
- 12 Limited Warranty Information

If, after reading your manual, you still have questions regarding this product, we recommend that you see your Rockford Fosgate dealer. If you need further assistance, you can call us direct at 1-800-669-9899. Be sure to have your serial number, model number and date of purchase available when you call.

PRACTICE SAFE SOUND

Continuous exposure to sound pressure levels over 100dB may cause permanent hearing loss. High powered auto sound systems may produce sound pressure levels well over 130dB. Use common sense and practice safe sound.

Safety

This symbol with "WARNING" is intended to alert the user to the presence of important instructions. Failure to heed the instructions will result in severe injury or death.



This symbol with "CAUTION" is intended to alert the user to the presence of important instructions. Failure to heed the instructions can result in injury or unit damage.



To prevent injury and damage to the unit, please read and follow the instructions in this manual. We want you to enjoy this system, not get a headache.

If you feel unsure about installing this system yourself, have it installed by a qualified Rockford Fosgate technician.

Before installation, disconnect the battery negative (-) terminal to prevent damage to the unit, fire and/or possible injury.

FCC Compliance Statement

This equipment has been tested and found to comply with the limits for a Class B digital device, pursuant to part 15 of the FCC Rules. These limits are designed to provide more reasonable protection against harmful interference in a residential installation.

Operation is subjected to the following two conditions: (1) This device may not cause harmful interference, and (2) the device must accept any interference received, including interference that may cause undesired operation.

This equipment generates, uses, and can radiate radio frequency energy and, if not installed and used in accordance with the instructions, may cause harmful interference to radio communications. However, there is no guarantee that interference will not occur in a particular installation. If this equipment does cause harmful interference to radio or television reception, which can be determined by turning the equipment off and on, you are encouraged to try to correct the interference by one of the following measures:

- Reorient or relocate the receiving antenna.
- Increase the separation between the equipment and receiver.
- Connect the equipment into an outlet on a circuit different from that to which the receiver is connected.
- Consult the dealer or an experienced radio/TV technician for help

©2015 Rockford Corporation. All Rights Reserved. PUNCH® and associated logos where applicable, are registered trademarks of Rockford Corporation in the United States and/or other countries. iPhone and iPod are trademarks of Apple Inc., registered in the U.S. and other countries. The Bluetooth® word mark and logos are registered trademarks owned by Bluetooth SIG, Inc. and any use of such marks by Rockford Corporation is under license. All other trademarks are the property of their respective owners. Specifications subject to change without notice.

"Made for iPod" and "Made for iPhone" mean that an electronic accessory has been designed to connect specifically to iPod, or iPhone, respectively, and has been certified by the developer to meet Apple performance standards. Apple is not responsible for the operation of this device or its compliance with safety and regulatory standards. Please note that the use of this accessory with iPod or iPhone may affect wireless performance.

Pandora, the Pandora logo, and the Pandora trade dress are trademarks or registered trademarks of Pandora Media, Inc. Used with permission. Pandora is only available in certain countries. Please visit <http://www.pandora.com/legal> for more information.

Model	PMX-2
Operating Voltage	10.5V - 16V
Fuse Rating	20A
Power Output	25 W X 4 @ 4 Ohms RMS 50 W x 4 @ 2 Ohms Peak
Max. RCA Output Voltage	4V
Output Impedance	500Ω
Frequency Response	20 - 20kHz
FM Frequency Range	87.5MHz - 107.9MHz
AM Frequency Range	530kHz - 1710kHz
WB Frequency Range	162.40 - 162.55 (US & Canada)
Tuner Presets	18 FM / 12 AM / 6 WB
Clock	No Clock
Display	2.7" Color TFT
Bluetooth	3.0+EDR, A2DP 1.3
USB Compatibility	2.0
USB Output	1A
Made for iPhone Model Names-	iPhone 6 Plus iPhone 6 iPhone 5S iPhone 5C iPhone 5 iPhone 4S iPhone 4 iPhone 3GS
Made for iPod Model Names	iPod Touch (5th generation) iPod Touch (4th generation) iPod Nano (7th generation) iPod Nano (6th generation)
Android Compatibility	Bluetooth® Only
Audio File Compatibility	MP3, WMA
Compatible Wired Remotes	PMX-1R, PMX-0R (3 Remote Limit, 100 ft Total Wired Distance)



CEA 2006
Power ratings on Rockford Fosgate source units conform to CEA-2006 industry standards. These guidelines mean your source unit's output power ratings are REAL POWER numbers, not inflated marketing ratings.

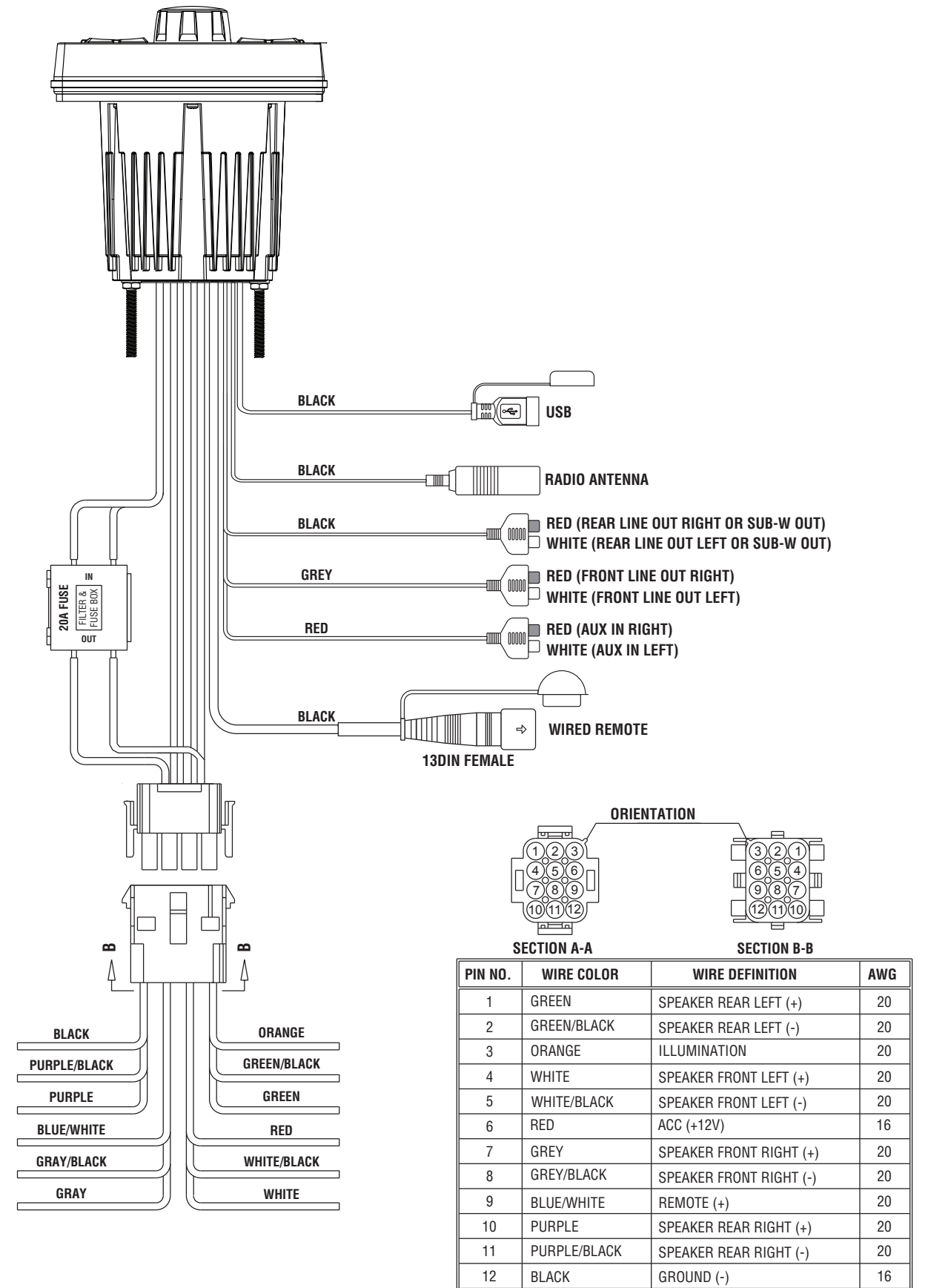
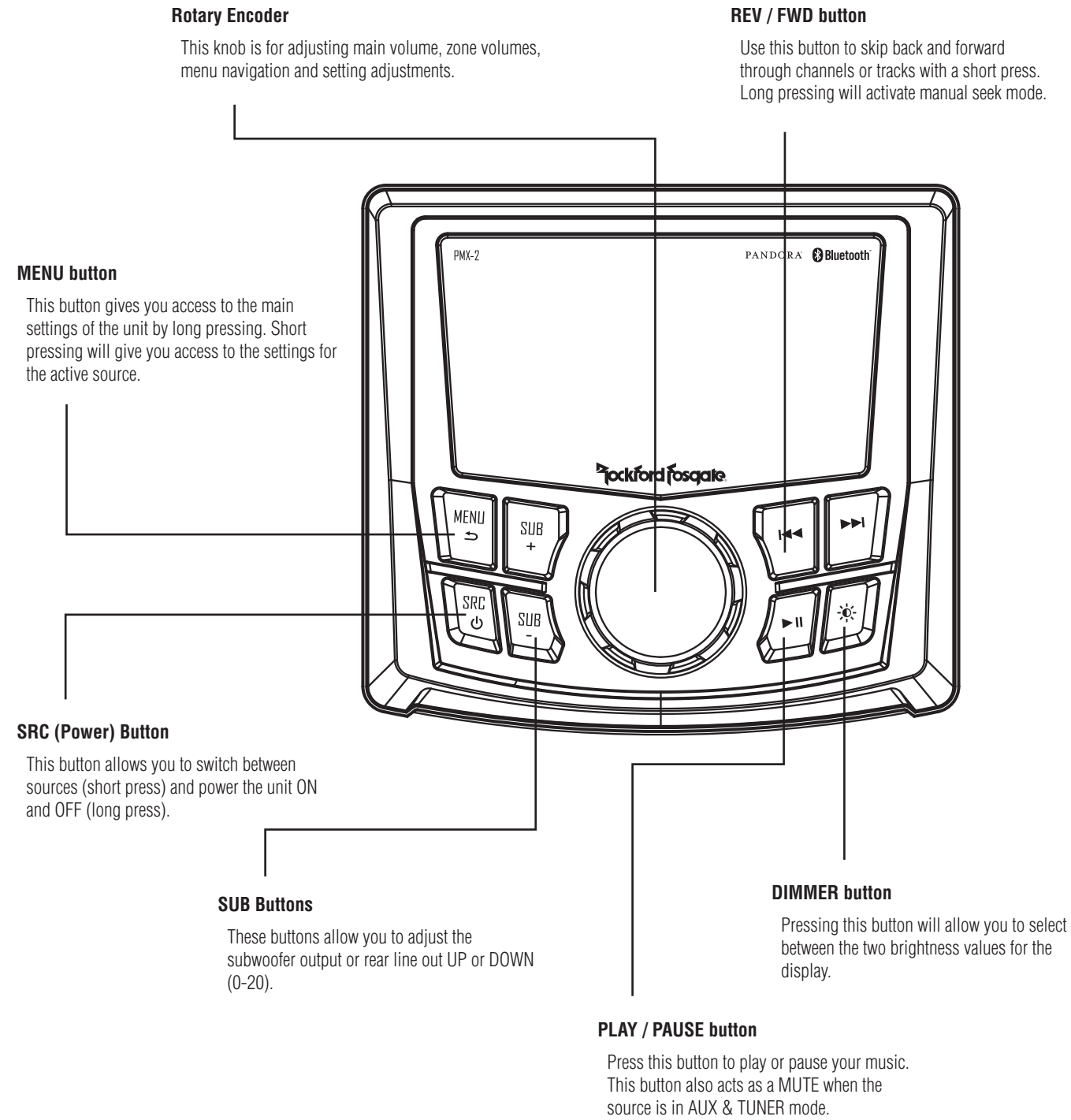

Contents

- Source Unit
- Trim Bezel
- Mounting Plate
- U Bracket
- Screws
- Power / Speaker Harness
- Installation & Operation Manual

Installation Considerations

The following is a basic list of tools needed for installation:

- Volt/Ohm meter
- Wire strippers
- Wire crimpers
- Wire cutters
- #2 Phillips screwdriver
- Battery post wrench
- Hand held drill w/ assorted bits
- Heat shrink tubing
- Soldering iron
- Solder
- Heat gun
- 7mm wrench

This section focuses on some of the vehicle considerations for installing your new source unit. Pre-planning your system layout and best wiring routes will save installation time. When deciding on the layout of your new system, be sure that each component will be easily accessible for making adjustments.

If you feel unsure about installing this system yourself, have it installed by a qualified Rockford Audio technician.

Before installation, disconnect the battery negative (-) terminal to prevent damage to the unit, fire and/or possible injury.

Before beginning any installation, follow these simple rules:

1. Be sure to carefully read and understand the instructions before attempting to install the unit.
2. For safety, disconnect the negative lead from the battery prior to beginning the installation.
3. For easier assembly, we suggest you run all wires prior to mounting your unit in place.
4. Route all of the RCA cables close together and away from any high current wires.
5. Use high quality connectors for a reliable installation and to minimize signal or power loss.
6. Think before you drill! Be careful not to cut or drill into gas tanks, fuel lines, brake or hydraulic lines, vacuum lines or electrical wiring when working on any vehicle.
7. Never run wires underneath the vehicle. Running the wires inside the vehicle provides the best protection.
8. Avoid running wires over or through sharp edges. Use rubber or plastic grommets to protect any wires routed through metal, especially the firewall.
9. ALWAYS protect the battery and electrical system from damage with proper fusing. Install the appropriate fuse holder and fuse on the +12V power wire within 18" (45.7 cm) of the battery terminal.
10. When grounding to the chassis of the vehicle, scrape all paint from the metal to ensure a good, clean ground connection. Grounding connections should be as short as possible and always be connected to metal that is welded to the main body, or chassis, of the vehicle. Seatbelt bolts should never be used for connecting to ground.

Mounting (Using Mounting Plate)

To mount the unit, you will need to find a flat surface with adequate clearance behind it that provides enough clearance for the unit and all it's necessary wiring.

1. Once you have determined a mounting location, you will need to cut a circular hole 3" (77mm) in diameter.
2. After the hole is cut slide the unit and wiring through the hole.
3. Slide the mounting plate over the backside of the unit and secure with the supplied screws.
4. Press on the trim bezel to the front side of the unit.
5. Plug in all wiring harnesses and cables. Refer to the wiring diagram for wire harness connection types.

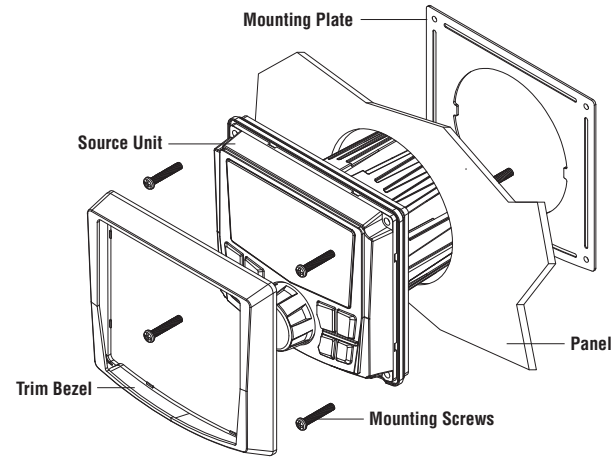

Mounting (Using U Bracket)

To mount the unit, you will need to find a flat surface with adequate clearance behind it that provides enough clearance for the unit and all it's necessary wiring.

1. Once you have determined a mounting location, you will need to cut a circular hole 3" (77mm) in diameter.
2. After the hole is cut slide the unit and wiring through the hole.
3. Take the U bracket and slide over the two studs on the back of the unit. Tighten down with supplied nuts.
4. Press on the trim bezel to the front side of the unit.
5. Plug in all wiring harnesses and cables. Refer to the wiring diagram for wire harness connection types.

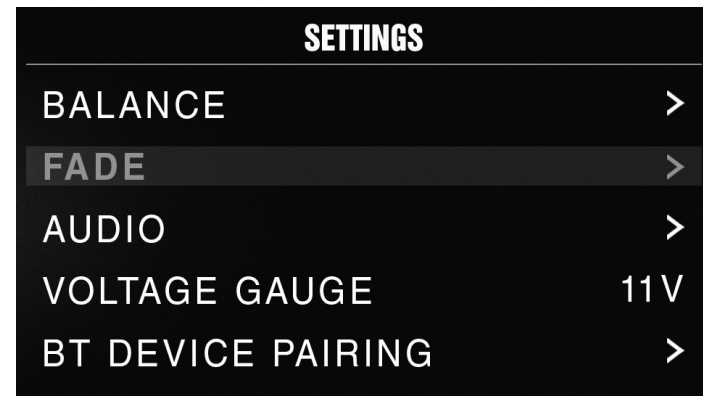
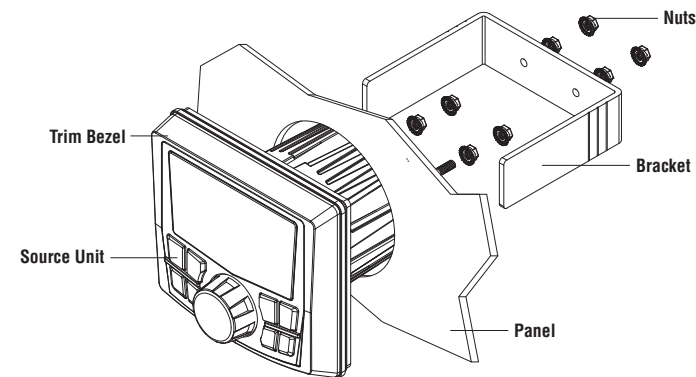

Source Unit Settings

To access the source unit's settings, long press the MENU button until the options appear. Rotate the encoder to scroll through the list of settings and short press the encoder button to select the setting you wish to change. (BALANCE>FADER>AUDIO>VOLTAGE GAUGE>BT PAIRING>BEEP>TUNER REGION>SOFTWARE>FACTORY DEFAULT)

This source unit has a zero current draw when turned off. All of your settings and presets will be saved along with your boat's battery during storage.

BALANCE

Short press the encoder button to access BALANCE adjustment settings. Rotate the encoder button to set output BALANCE.

FADER

Short press the encoder button to access FADER adjustment settings. Rotate the encoder button to set output FADER.

AUDIO

To access the AUDIO settings, short press the AUDIO option from the MENU screen. Rotate the encoder to scroll through the list of settings and short press the encoder button to select the setting you wish to change. (7 BAND EQ>CROSSOVER>PEQ>REAR RCA>AUX INPUT>SOURCE GAIN>INTERNAL AMPLIFIER)

7 BAND EQ

Short press the encoder button to access the 7 BAND EQ settings. Use the rotary encoder to scroll through the EQ settings. (FLAT > ROCK > CLASSIC > ACOUSTIC > DANCE > ELECTRONIC > HIP-HOP > CUSTOM) When setting up the CUSTOM EQ, short press the encoder button to set the first frequency. Once active, rotate the encoder to adjust the frequency settings. Short press encoder button again to access the next frequency. Repeat until all EQ settings are complete. Short press the MENU button to exit and go back up one level.

CROSSOVER

Short press to access the CROSSOVER settings. Use the rotary encoder to select the crossover zone options (FRONT>REAR>SUB). Short press the encoder to adjust the frequency of the crossover (60Hz>80Hz>120Hz>APF). Short press MENU to exit and go back up one level.

REAR RCA

Short press to access the REAR RCA options. Use the rotary encoder to select options (LINE OUT>SUBWOOFER).

PUNCH EQ

Short press to access the PUNCH EQ settings. Use the rotary encoder to adjust the gain output (0-12). Short press MENU to exit and go back up one level.

Punch EQ is an onboard equalizer with up to +18dB @ 45Hz and/or up to +12dB boost at 12.5kHz

AUX INPUT

RENAME – To rename AUX, short press the encoder button to set the first letter of the new name. Once active, rotate encoder to adjust letters. Short press the encoder button again to set the next letter. Repeat until AUX has been renamed. Short press MENU to exit and go back up one level.

ENABLE - Short press the encoder button to access options. Rotate the encoder button to select if unit is discoverable. (ENABLE > DISABLE)

SOURCE GAIN

To adjust the level of device input gain, scroll through the inputs (FM TUNER>AM TUNER>WB TUNER>USB>AUX>BLUETOOTH>PANDORA) to the device you want to adjust, short press the encoder button to access the gain settings. Rotate the encoder button to set the level of gain. (-3dB > -2dB > -1dB > 0dB > +1dB > +2dB > +3dB)

INTERNAL AMPLIFIER

Short press to access the INTERNAL AMPLIFIER options. Use the rotary encoder to select options (ON>OFF). When using an amplifier to power your speakers, select OFF. If you are powering your speakers directly from the source unit, select the INTERNAL AMPLIFIER to ON.

VOLTAGE GAUGE

To display the vehicle voltage, short press the encoder button on the VOLTAGE GAUGE option.

BT DEVICE PAIRING

Short press the encoder button to access options. Rotate the encoder button to select if unit is discoverable for pairing. (ENABLE > DISABLE) Once enabled, the source unit is now discoverable and ready for pairing to your device. Open the Bluetooth settings on your device to find the source unit labeled "Rockford PMX" and select.

BEEP

Short press the encoder button to access the BEEP options. Rotate the encoder button to turn system beep ON/ OFF.

TUNER REGION

To adjust, short press the encoder button to access. Rotate the encoder button to select the TUNER REGION of your preference. (EUROPE > USA > RUSSIA > LATIN > ASIA > JAPAN > MIDEAST > AUSTRALIA)

SOFTWARE

VERSION - Short press the encoder button to display the current firmware version of the unit.

UPDATE - Short press the encoder button to update the firmware. Follow the instructions on the screen when updating.

FACTORY DEFAULT

AUDIO – Short press the encoder button to access. Rotate the encoder button to select YES/NO. Selecting YES will reset your unit back to factory default settings.

SYSTEM - Short press the encoder button to access. Rotate the encoder button to select YES/NO. Selecting YES will reset your unit back to factory default settings.

Basic Operation

TURNING THE UNIT ON / OFF

Long press the SRC (Power) button to turn the unit ON or OFF

ADJUSTING THE VOLUME

Rotate encoder knob left or right to desired volume level (0-40). The current volume level will be displayed during adjustment.

ADJUSTING THE SUBWOOFER OUTPUT

Press the SUB + or SUB- buttons to adjust the output level (0-20).

ADJUSTING THE SCREEN BRIGHTNESS

Short press the SCREEN BRIGHTNESS button to adjust the brightness level. There are two brightness levels.

SELECTING A SOURCE TO PLAY

Short press the SRC button to show the different source options (FM TUNER>AM TUNER>WB TUNER>USB>AUX>BLUETOOTH>PANDORA>SIRIUSXM). Use the rotary encoder or short press the SRC button to scroll through sources.

**Tuner Operation (FM/AM/WB)**

To operate, use the rotary encoder to select the tuner source you want to listen to (FM>AM>WB).

To AUTO SEEK stations, short press the FWD and REV buttons. To MANUAL SEEK stations, long press the FWD and REV buttons to tune to the desired frequency.

To MUTE the TUNER, short press the PLAY/PAUSE button.

FM BAND SETTINGS

To access the FM BAND SETTINGS, short press the MENU when using the FM TUNER source. This will give you access to the settings specific to the FM TUNER (FM>PRESETS>ADD PRESETS>REMOVE PRESETS>AUTO STORE>LOCAL).

PRESETS

Short press the encoder button to access the PRESETS list. Using this feature allows you to see what PRESETS are saved on the unit.

ADD PRESETS

Short press the encoder button on the ADD PRESETS option. You will need to be on both the station and PRESET group you want to add first (FM1>FM2>FM3). Using this feature allows you to save stations to the unit. Once selected, use the rotary encoder to select the PRESET number (1-6) you want the station saved to.

REMOVE PRESETS

Short press the encoder button on the REMOVE PRESETS option. You will need to be under the PRESET group you want to adjust first (FM1>FM2>FM3). Using this feature allows you to remove saved stations on the unit. Once selected, use the rotary encoder to select the PRESET number (1-6) of the station you want removed.

FM

Short press the encoder button to access the FM PRESET options (FM1>FM2>FM3). Using this feature allows you to have separate tuner preset groups to choose from. Use the rotary encoder button to scroll through the TUNER groups and short press to select the group.

AUTO STORE

Short press the encoder button to access the AUTO STORE function. You will need to be under the PRESET group you want to adjust first (FM1>FM2>FM3). This feature automatically stores presets on the unit. It will stop when presets 1-6 are set. Select the next PRESET group and repeat to fill next set.

LOCAL

Short press the encoder button to access the LOCAL options. Once selected, use the rotary encoder to select ON or OFF. The local option tunes to nearby radio stations with sufficiently strong signals for good reception. In areas where reception is poor, switching to distance tuning enables the unit to tune in to more distant stations. Distance tuning is the default.

AM BAND SETTINGS

To access the AM BAND SETTINGS, short press the MENU when using the AM TUNER source. This will give you access to the settings specific to the AM TUNER (AM>PRESETS>ADD PRESETS>REMOVE PRESETS>AUTO STORE>LOCAL).

PRESETS

Short press the encoder button to access the PRESETS list. Using this feature allows you to see what PRESETS are saved on the unit.

ADD PRESETS

Short press the encoder button on the ADD PRESETS option. You will need to be on both the station and PRESET group you want to add first (AM1>AM2). Using this feature allows you to save stations to the unit. Once selected, use the rotary encoder to select the PRESET number (1-6) you want the station saved to.

REMOVE PRESETS

Short press the encoder button on the REMOVE PRESETS option. You will need to be under the PRESET group you want to adjust first (AM1>AM2). Using this feature allows you to remove saved stations on the unit. Once selected, use the rotary encoder to select the PRESET number (1-6) of the station you want removed.

AM

Short press the encoder button to access the FM PRESET options (AM1>AM2). Using this feature allows you to have separate tuner preset groups to choose from. Use the rotary encoder button to scroll through the TUNER groups and short press to select the group.

AUTO STORE

Short press the encoder button to access the AUTO STORE function. You will need to be under the PRESET group you want to adjust first (AM1>AM2). This feature automatically stores presets on the unit. It will stop when presets 1-6 are set. Select the next PRESET group and repeat to fill next set.

LOCAL

Short press the encoder button to access the LOCAL options. Once selected, use the rotary encoder to select ON or OFF. The local option tunes to nearby radio stations with sufficiently strong signals for good reception. In areas where reception is poor, switching to distance tuning enables the unit to tune in to more distant stations. Distance tuning is the default.

WB BAND SETTINGS

To access the WB BAND SETTINGS, short press the MENU when using the WB TUNER source. This will give you access to the settings specific to the WB TUNER (PRESETS>ADD PRESETS>REMOVE PRESETS).

PRESETS

Short press the encoder button to access the PRESETS list. Using this feature allows you to see what PRESETS are saved on the unit.

ADD PRESETS

Short press the encoder button on the ADD PRESETS option. You will need to be on both the station you want to add first. Using this feature allows you to save stations to the unit. Once selected, use the rotary encoder to select the PRESET number (1-6) you want the station saved to.

REMOVE PRESETS

Short press the encoder button on the REMOVE PRESETS option. You will need to be under the PRESET group you want to adjust first (AM1>AM2). Using this feature allows you to remove saved stations on the unit. Once selected, use the rotary encoder to select the PRESET number (1-6) of the station you want removed.

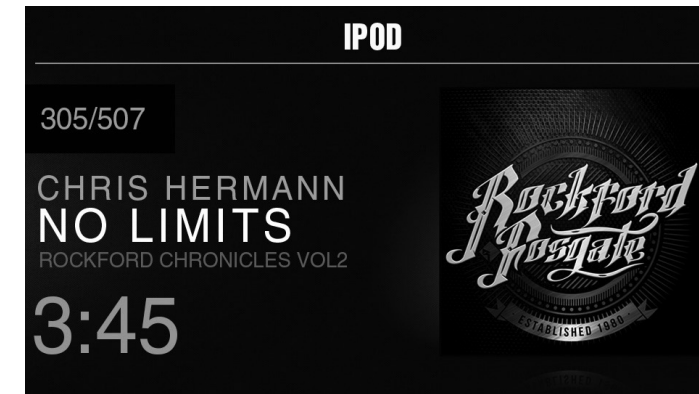
**USB (iPod) Operation**

After your device is connected to the source unit, this feature allows you to control playback from your device directly from the unit. Select the USB source option on the source unit.

To play or pause a song, short press the PLAY/PAUSE button.

To skip a track forward, short press the FWD button. To skip a track backwards, short press the REV button.

To access USB specific settings, short press the MENU button for the list of settings (BROWSER>REPEAT>SHUFFLE). Use the encoder to select the option to change.

BROWSER

Short press the encoder button to access the BROWSER options (PLAYLISTS>ARTISTS>ALBUMS>GENRES>SONGS>COMPOSERS>AUDIOBOOKS>PODCASTS). Using this feature allows you to search for tracks or songs by different types of categories.

REPEAT

Short press the encoder button to access the REPEAT feature options (OFF>ONE>ALL).

SHUFFLE

Short press the encoder button to access the SHUFFLE feature options (OFF>ALL). This feature allows you to set your preference on shuffling tracks or songs.

**AUX Operation**

After your device is plugged into the source unit, this feature allows you to play music from your device. Select the AUX source option on the source unit and use your plugged in device to control song/track selection, PLAY/PAUSE and track skip FWD/REV.

**Bluetooth® Operation**

After your device is paired to the source unit, this feature allows you to control playback from your device directly from the unit. Select the BLUETOOTH source option on the source unit.

To play or pause a song, short press the PLAY/PAUSE button.

To skip a track forward, short press the FWD button. To skip a track backwards, short press the REV button.

To access BLUETOOTH specific settings, short press the MENU button for the list of settings (BROWSER>REPEAT>SHUFFLE). Use the encoder to select the option to change.

BROWSER

Short press the encoder button to access the BROWSER options (PLAYLISTS>ARTISTS>ALBUMS>GENRES>SONGS>COMPOSERS>AUDIOBOOKS>PODCASTS). Using this feature allows you to search for tracks or songs by different types of categories.

REPEAT

Short press the encoder button to access the REPEAT feature options (OFF>ONE>ALL). This feature allows you to set your preference on the amount of times a track or song will repeat.

SHUFFLE

Short press the encoder button to access the SHUFFLE feature options (OFF>ALL). This feature allows you to set your preference on shuffling tracks or songs.

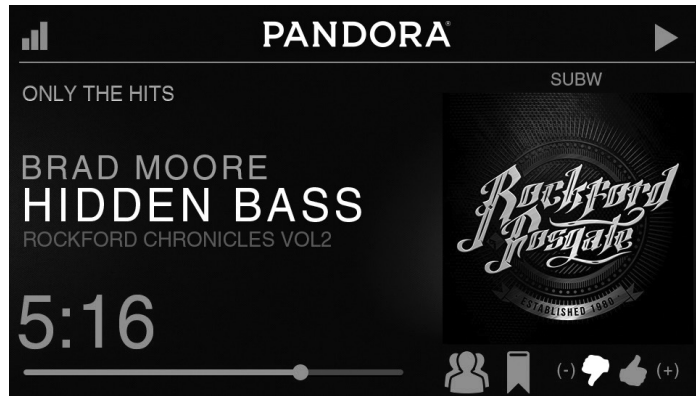

Pandora®

This feature allows you to control the Pandora® app from the source unit directly (Android users will have to use Bluetooth only, iOS users can use both USB and Bluetooth). You will need to start the Pandora® app on your device first, then select the Pandora® source option on the source unit. To use the “Thumbs Up” feature, long press the SUB+ button. To use the “Thumbs down” feature, long press the SUB - button.

To play or pause a song, short press the PLAY/PAUSE button.

To skip a track forward, short press the FWD button.

To access Pandora® specific settings, short press the MENU button for the list of settings (STATIONS>BOOKMARKS>STATIONS MANAGE). Use the encoder to select the option to change.

STATIONS

To adjust, short press the encoder button to access. Rotate the encoder button to select your options (SHUFFLE>SORT DATE/A-Z>STATIONS). Selecting the SHUFFLE option will shuffle your stations and selecting the SORT feature will sort your stations by date added or alphabetically. You can also select your saved stations directly from this list.

BOOKMARKS

To BOOKMARK an artist or track that is playing, short press the encoder button to display your BOOKMARK options (ARTIST>TRACK). Select the option you wish to use for bookmarking.

STATIONS MANAGE

To create stations, short press the encoder button to display your STATION MANAGE options (CREATE FROM ARTIST> CREATE FROM TRACK> CREATE FROM GENRE>DELETE). Selecting the CREATE FROM ARTIST OPTION allows you to create a station from the artist that you are currently listening to. CREATE FROM TRACK works similarly by creating a station from the current track being played. If you create a station by selecting CREATE FROM GENRE, this will give you music genres to select from to create your station. Selecting DELETE will delete the now playing station.

Pandora, the Pandora logo, and the Pandora trade dress are trademarks or registered trademarks of Pandora Media, Inc. Used with permission. Pandora is only available in certain countries. Please visit <http://www.pandora.com/legal> for more information.

Symptom	Diagnosis	Remedy
Basic		
Source unit does not turn on.	Blown fuse	Check fuse of the unit, replace with correct rating.
	Vehicle's ignition is off	If connected following the instructions, the unit will not operate with ignition off.
	Voltage applied to Red wire is not between 10.5 & 16 volts or there is no voltage present	Check battery, connections and fuses and repair or replace as necessary. If voltage is above +16 volts, have the electrical system inspected by an authorized service center.
	Unit is not properly grounded	Check wiring and repair as necessary.
Radio Tuner		
Tuner fails to tune any stations	No antenna or disconnected or open connection in cable	Check all connections and repair as necessary.
Unable to tune stations in seek mode	You are in a weak signal area	Make sure the tuner LOC mode is off.
USB Devices		
USB device cannot be inserted	The USB device has been inserted in the wrong direction	Reversing the connection direction of the USB device, try reinserting.
	The USB device connector is broken	Replace with a new USB device.
USB device is not recognized	The USB device is damaged	Disconnect USB device and reconnect. If the device is still not recognized, try replacing with a different USB device. USB does not work with Android devices.
	Connectors are loose	
No sound heard with the display “No File” shown	No MP3/WMA files are stored on the USB device	Store these files properly on the USB device. USB does not work with Android devices.
Sound skips or is noisy	MP3/WMA files are not created properly	Use MP3/WMA files that are encoded correctly.
AUX		
MP3 is not playing back	Writing error occurred. The MP3 format is not compatible.	Make sure MP3 has been written in a supported format

Rockford Corporation offers a limited warranty on Rockford Fosgate products on the following terms:

Length of Warranty

POWER Amplifiers – 2 Years
BMW® Direct Fit Speakers – 2 Years
Source Units – 1 Year
All other products – 1 Year
Any Factory Refurbished Product – 90 days (receipt required)

What is Covered

This warranty applies only to Rockford Fosgate products sold to consumers by Authorized Rockford Fosgate Dealers in the United States of America or its possessions. Product purchased by consumers from an Authorized Rockford Fosgate Dealer in another country are covered only by that country's Distributor and not by Rockford Corporation.

Who is Covered

This warranty covers only the original purchaser of Rockford product purchased from an Authorized Rockford Fosgate Dealer in the United States. In order to receive service, the purchaser must provide Rockford with a copy of the receipt stating the customer name, dealer name, product purchased and date of purchase.

Products found to be defective during the warranty period will be repaired or replaced (with a product deemed to be equivalent) at Rockford's discretion.

What is Not Covered

1. Damage caused by accident, abuse, improper operations, water, theft, shipping.
2. Any cost or expense related to the removal or reinstallation of product.
3. Service performed by anyone other than Rockford or an Authorized Rockford Fosgate Service Center.
4. Any product which has had the serial number defaced, altered, or removed.
5. Subsequent damage to other components.
6. Any product purchased outside the U.S.
7. Any product not purchased from an Authorized Rockford Fosgate Dealer.

Limit on Implied Warranties

Any implied warranties including warranties of fitness for use and merchantability are limited in duration to the period of the express warranty set forth above. Some states do not allow limitations on the length of an implied warranty, so this limitation may not apply. No person is authorized to assume for Rockford Fosgate any other liability in connection with the sale of the product.

How to Obtain Service

Contact the Authorized Rockford Fosgate Dealer you purchased this product from. If you need further assistance, call 1-800-669-9899 for Rockford Customer Service. You must obtain an RA# (Return Authorization number) to return any product to Rockford Fosgate. You are responsible for shipment of product to Rockford.

EU Warranty

This product meets the current EU warranty requirements, see your Authorized dealer for details.